

FRAME'S COUNTERSINKING

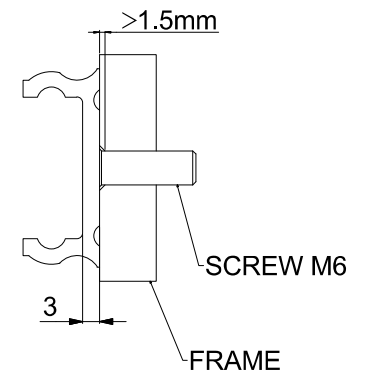

- 1 - Linear rail E53P + Plastic cap (BE 559)
- 2 - Carrier G53 with pivot assembly (BE 531)
- 3 - Right front bracket (BE 530)
- 4 - Left front bracket (BE 530)

LOAD FOR A SET : 100 Kg

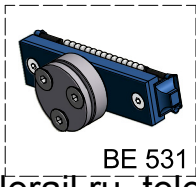

- OPTIONS:
 Length of rail, Ø and hole pattern to customer's requirement

- Dimensions in mm
- Maxi speed of use: 0.5 m/s
- DO NOT REMOVE CARRIERS FROM THE LINEAR RAILS!

FT801	E53GP	CHAMBRELAN
A0	01.08.12	